

# CHAPMAN

HEAVY DUTY ATV MACHINERY

---

US/CANADA  
PRODUCT BROCHURE  
2021

# OUR STORY

**Chapman Machinery Ltd is an innovative design and manufacturing company producing products for equestrian, agricultural and estate management sectors.**

From humble beginnings manufacturing ATV Trailers, the company has grown rapidly through continual investment in people, plant and machinery to produce a range of quality labour saving machinery.

We offer a two year parts warranty for peace of mind on all of our machines and work in partnership with local distributors to ensure our customers have a local point of contact for advice on getting the best out of your machine and to source any spares that may be required.

With dedicated design, manufacturing and assembly premises in the South West of England, Chapman Machinery Ltd proudly manufacture our products in Great Britain. Over 50% of our production is exported worldwide, using local distribution partners.

## **Our Aim**

At Chapman Machinery Ltd our focus is on making a quality product that is easy to use.

Quality design and the utilisation of advanced manufacturing techniques ensure our products are of exceptional quality, yet represent great value. We aim to be a global manufacturer and are building towards this goal by ensuring we create great products of exceptional quality, backed by outstanding support.

## **James Chapman**

Director



# PRODUCTS

06



**FM PRO SERIES**  
FLAIL MOWER

10



**PC120**  
POWER COLLECTOR

12



**BT500**  
BALE TRAILER

14



**MG250**  
ARENA LEVELLER





# BRITISH MANUFACTURING AT ITS BEST

Every machine we produce is designed, fabricated and built on site. From raw steel through to a finished product we manage the process, giving us control over the quality. We proudly manufacture each and every product in the United Kingdom.

# DESIGN

Every machine starts its journey with a full CAD design. This allows every part to be checked for form, fit and function before fabrication.

New designs are built, tested and approved before the design progresses to full production. At this stage, engine powered equipment is independently tested by Honda so that each product is fully warranty approved.

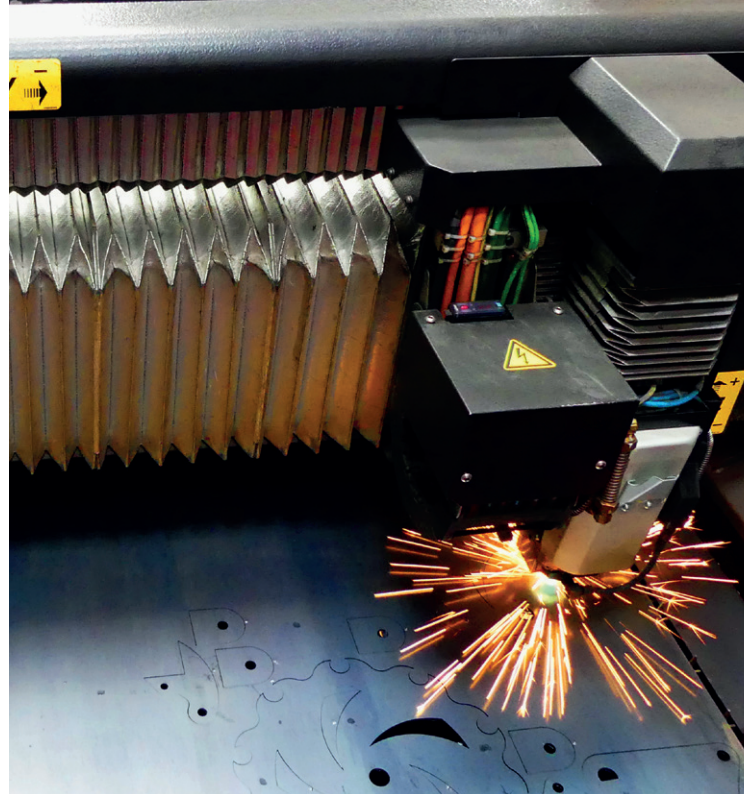

# FINISH

All machines are shot blasted and powder coated on site. Shot blasting cleans the steelwork and provides a key for the paint to adhere strongly to, giving an even, glossy and hard-wearing finish.

We powder coat the machines in our trademark orange and black paint. We use powder coating as it is a very hard wearing finish and is considerably more environmentally friendly than traditional wet spray painting.

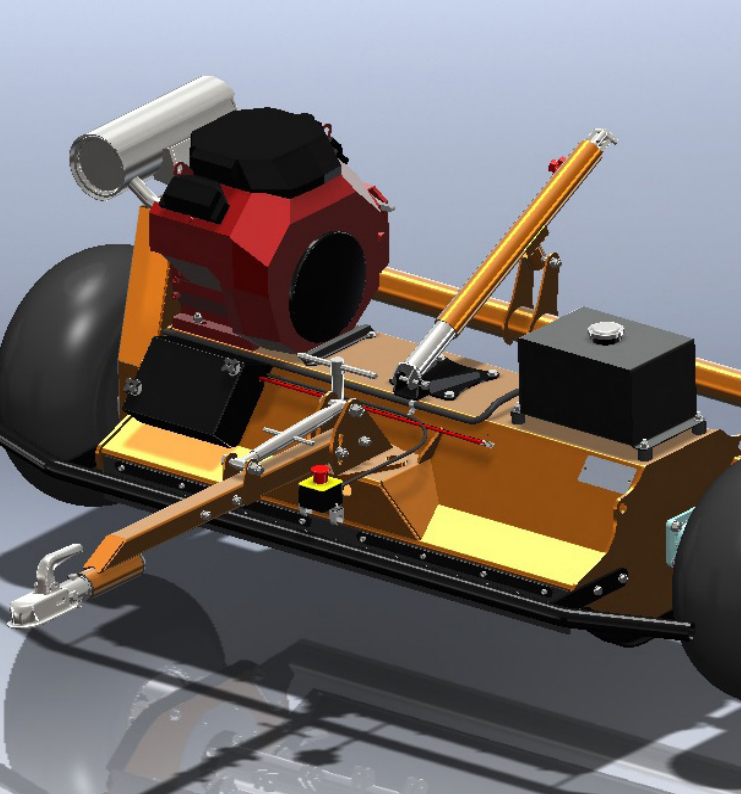

# FABRICATE

Once the design is finished, tested and approved, the steel is laser cut and folded to the correct forms all in-house. We use laser profiling as it is the most accurate form of cutting large volumes of steel, ensuring precision and conformity of every product produced.

Critical parts such as bushes and bearings are CNC machined to the highest tolerances for accuracy.

All of the components are brought together and fully fabricated on site. This ensures all frames and components are made to measure before progressing for finishing.

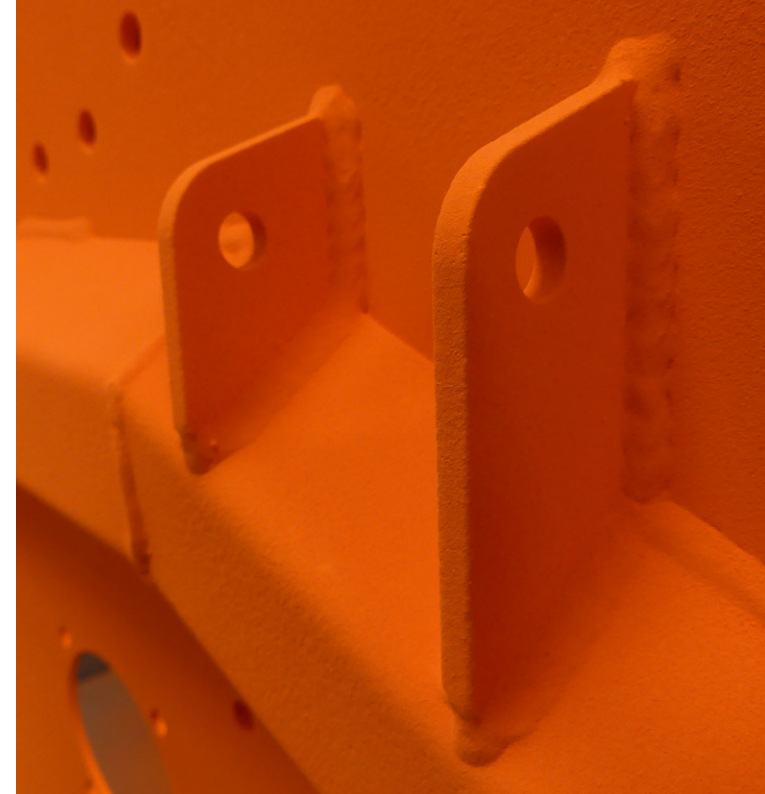

# FM PRO SERIES FLAIL MOWER



Model shown **FM120 PRO**



**Designed for the full range of topping and mowing tasks, from thick dense overgrowth to fine topping of parkland, the FM series Flail Mowers can tackle anything thrown at them. Extremely robust build with fine attention to detail ensures these mowers withstand years of use. Available in 4'ft (1.3m) and 5'ft (1.5m) cut widths.**

The FM Pro Flail Mower features a robust steel flail rotor, balanced to exacting tolerances for smooth operation, operating in a horizontal plane. This allows the cutting flails to fold back if an obstruction is encountered, to prevent damage to the machine.

Powered by a 23hp Fuel Injected V-twin Honda engine, with integrated electric start, to give plenty of cutting power when needed, but in an easy to start and use package. Large flotation tyres can be set to run beside the cutting deck – for ease of towing and attachment – or behind the cutting deck – to enable cutting close to fences and hedges.

The FM Pro is designed specifically to meet all US & Canada state laws including a large 5 gallon fuel tank with carbon canistor for improved emissions. Simple height adjustment for ease of use and an automatic belt tensioning system with robust B Section drive belts for low-maintenance ownership, complete the package.



Wheels trailing the machine (to enable cutting close to hedges and fences).

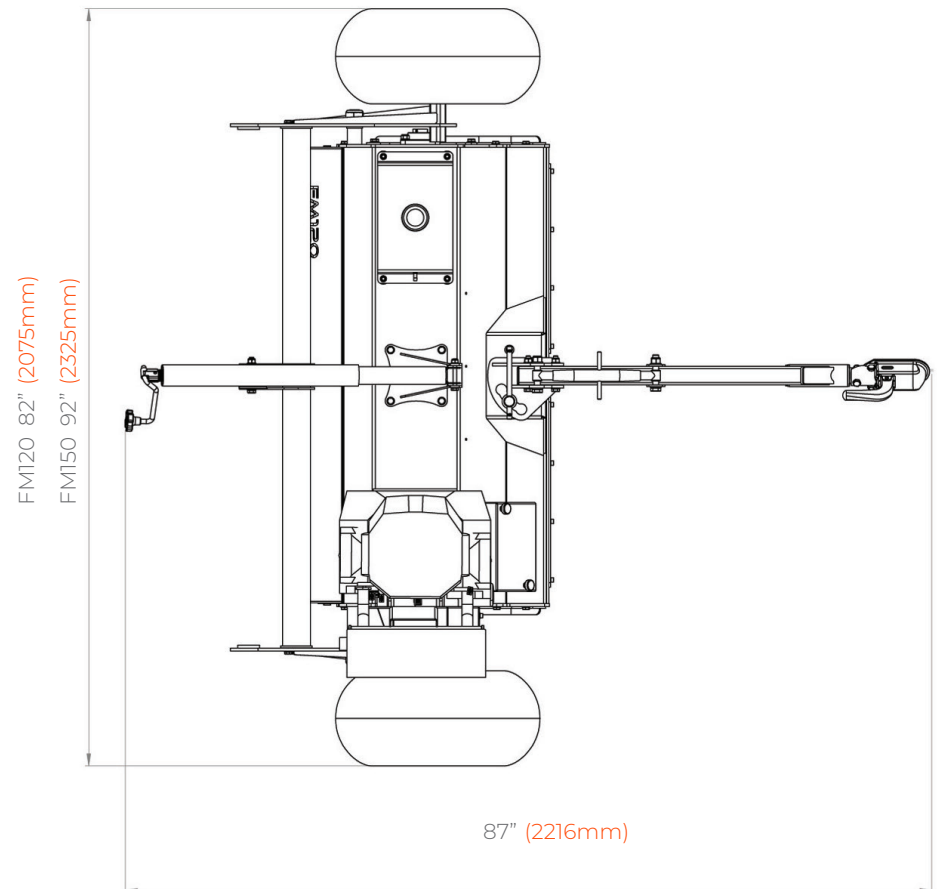
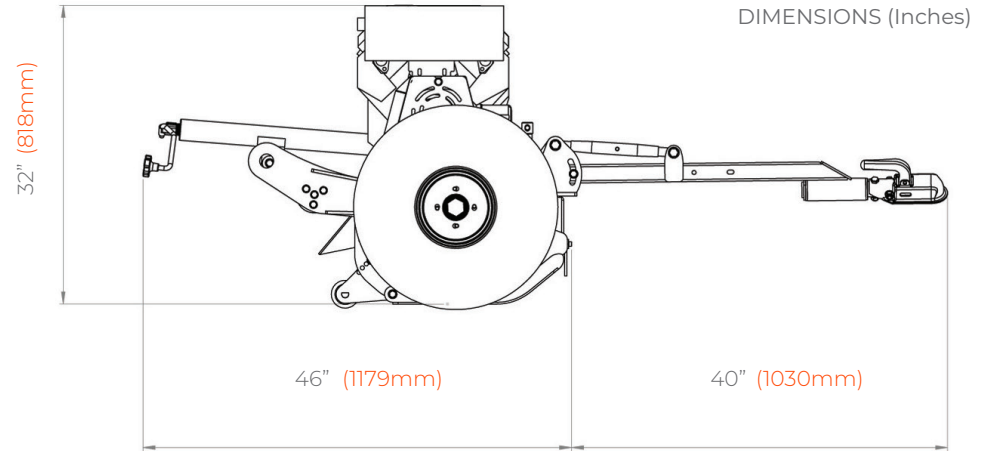

## TECHNICAL FEATURES

- Powerful 23hp Fuel Injected Honda engine with 3 year Honda warranty
- Heavy duty construction throughout the machine
- Unique double helix flail rotor, precision balanced for smooth operation
- Large diameter tyres for smooth travel over uneven arenas
- Automatic belt tensioning system for low maintenance
- Drawbar can be offset left and right
- Easy cutting height adjustment



## FM Series Options



### Front Breaker Bar

Ensures tall materials (e.g reeds or bracken) feed evenly into the rotor for consistent cutting performance



### Chop Control Cutter Bar

Adjustable cutting bar within the deck to increase mulching and speed breakdown of cut material

The FM PRO model features a Honda iGX700 as standard, with 23hp out of the box, excellent fuel efficiency and low emissions. This is paired with forged hammer flails as standard, proven to cope with the most demanding growth.

The ultimate machine for any application - go where other machines cannot.

SPEC	FM US SPEC
Engine	Honda iGX700 EFI
Power	23hp
Start-up	Electric Start
Flail Type	Hardened Hammer Flails (22 FM120/26 FM150)
Weight	675lbs (FM120) / 715lbs (FM150)
Cutting Height (inches)	1"-10"
Rotor RPM	2400
Rotor Balancing Grade	G6.3 Dynamic Balance
Clutch	Heavy Duty Double Flyweight Centrifugal Clutch
Tyre Size	22x11x8"
Fuel Tank Capacity (Gallon)	5
Drive belt size	2 x BX41

## UNIQUE SPIRAL ROTOR DESIGN

Our innovative rotor design incorporates a solid 40mm diameter drive shaft right through the centre of the rotor with a structural grade 90mm diameter outer tube, onto which the flail lugs are welded in a spiral pattern. This unique design transfers cutting power more efficiently from the engine to the cutting heads, giving a cleaner cut and better performance in tough situations.

Furthermore the rotor incorporates dedicated bearing guards designed to prevent string and wire damaging the bearings.

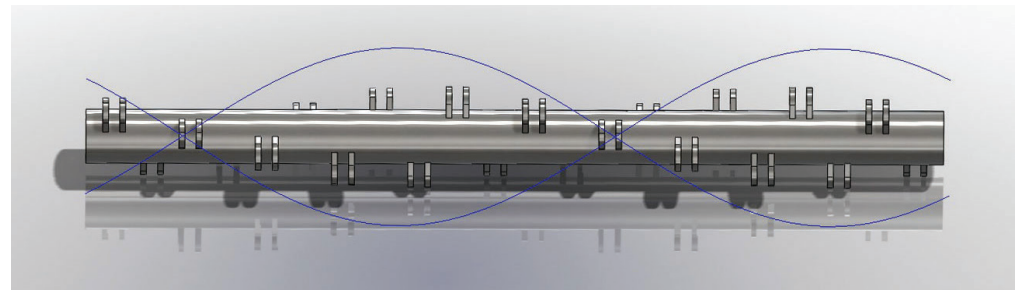



# MORE POWER. LESS FUEL.

EFI Fuel Injection Technology For The Ultimate Efficiency



FM **PRO**

# PC120

## POWER COLLECTOR



Electric Hopper Emptying



**The PC120 Power Collector is a 4ft working width Manure & Leaf Collector designed for effortless pasture maintenance. The PC120 is a self-powered towed unit for use behind almost any vehicle equipped with a 2" ball. Sweeping up leaves, manure and other debris can be a tedious task by hand, the PC120 makes a strenuous maintenance task quick and simple, keeping your pasture clean and healthy.**

The PC120 is powered by a reliable 6.5hp Honda GX200 Engine and centrifugal clutch system which engage 4 heavy duty brushes on nylon carriers to lift up dung and other loose debris with ease. The paddock cleaner also features a fully adjustable Tine Bar as standard to help break up compacted dung for more stubborn paddocks.

The Electric Emptying Hopper comes with a remote tipping mechanism for ease of use from the seat of your ATV/UTV. This makes for effortless emptying of the large 120 Gallon hopper, removing the need for hand winching and locking mechanisms of similar competitor machines.

#### TECHNICAL FEATURES

- Robust deck and build with laser cut vents
- Remote electric empty hopper for ease of use
- Single axle for easy manoeuvrability
- IP69 Sealed Electrics
- 8 quality steel tines to help break up stubborn dung piles
- Heavy duty brushes for longevity
- Large diameter tyres for smooth travel over uneven arenas
- Tried and tested British manufactured

SPEC	PC120
Weight(Unladen)	660lbs
Engine	6.5hp GX200 Honda with Electric Start
Hopper Size	120 Gallon Hopper
Tyre Size	19 x 7 x 8"
Working Width	4ft (1.2m)

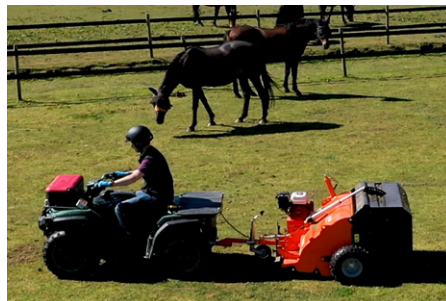

DIMENSIONS (Inches)

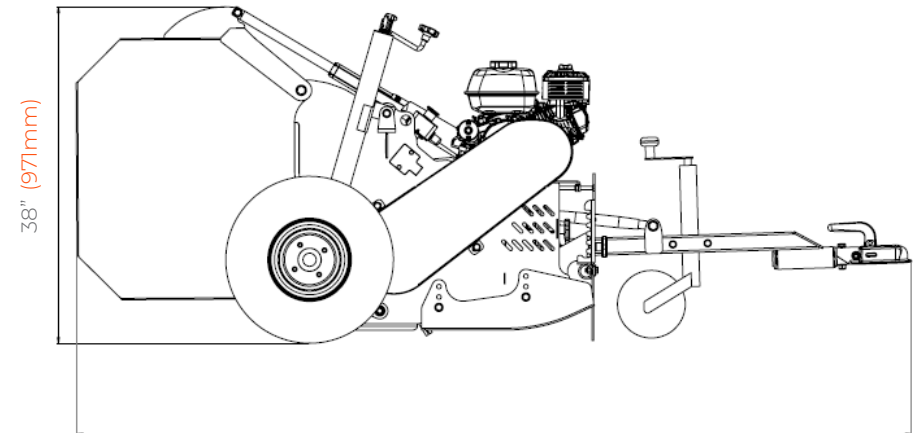

95" (2422mm)

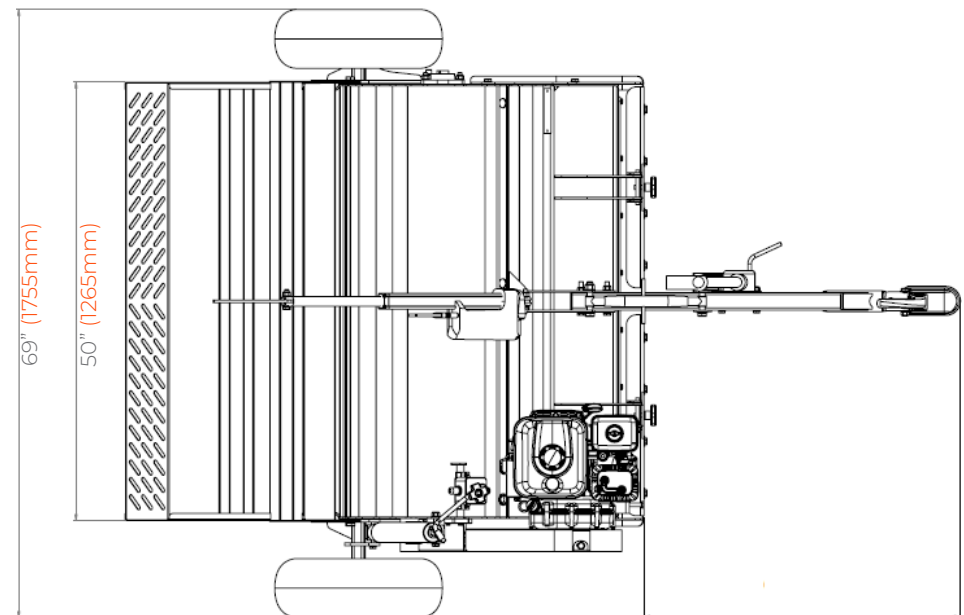

36" (910mm)

# BT500

## BALE TRAILER



Wireless Remote  
Winch

**The BT500 Round Bale Trailer is a simple yet robust tool for the transportation of round baled feed such as hay, straw or silage to wet ground beyond the reach of a conventional loader or tractor, or where a loader / tractor is not available.**

Designed for use behind an ATV, UTV or 4x4 (off-road only) the low ground pressure and relatively light weight of the BT500 allows it to travel easily over rough or wet ground with its twin axle wheel configuration for feeding out-wintered stock. Alternatively, the BT500 can be used on smallholdings and in equestrian yards where a tractor is not available, allowing round bales to be used in place of small square bales at a considerable cost saving. The BT500 features an electric winch for loading and unloading the bale as standard, along with a remote control. This allows even the heaviest bales to be loaded with ease, and makes hitching and un-hitching the bale transporter quick and easy with just one small electrical plug connection to be made.

The innovative design of the BT500 round bale transporter means that the cradle arms automatically grip the bale as it is reversed up to it for loading, with only one small ratchet strap to be attached before the bale can be loaded securely and safely using the remote winch control.

**TECHNICAL FEATURES**

- Electric winch for easy loading & unloading of bales
- Robust galvanised steel chassis
- Twin axle configuration for better travel across rough ground
- Remote control operation



SPEC	BT500
Working Width	5'7"ft
Weight (Unladen)	440lbs
Max Bale Weight	2000lbs
Max Bale Diameter	5ft
Max Bale Length	5ft
Tyre Size	22 x 11 x 8"

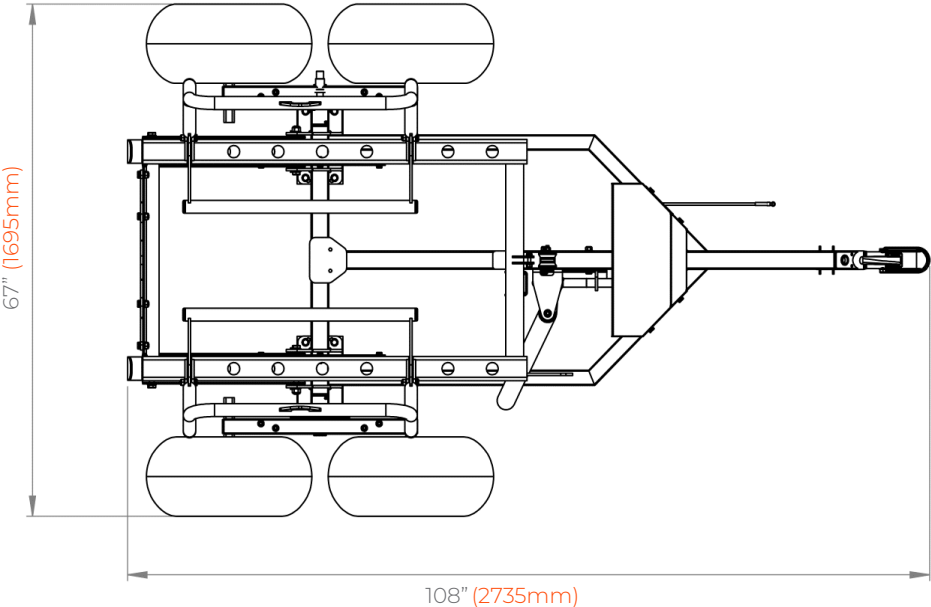
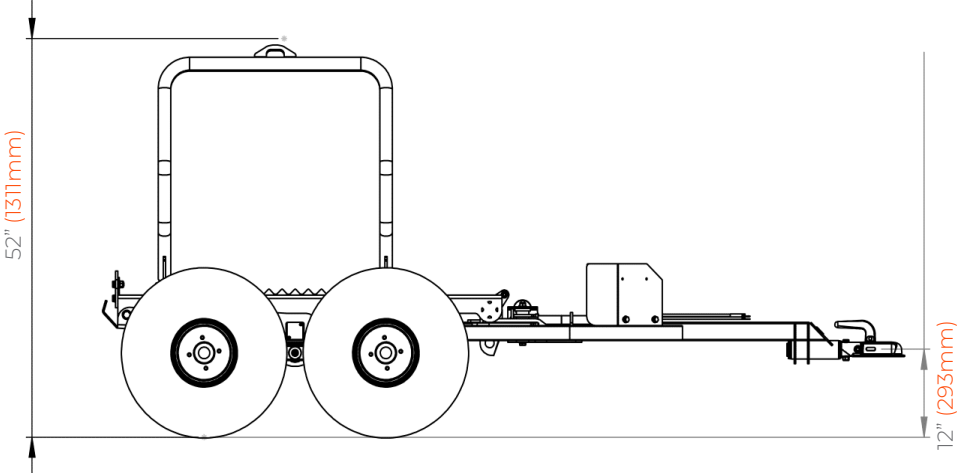

# MG250

## ARENA LEVELLER

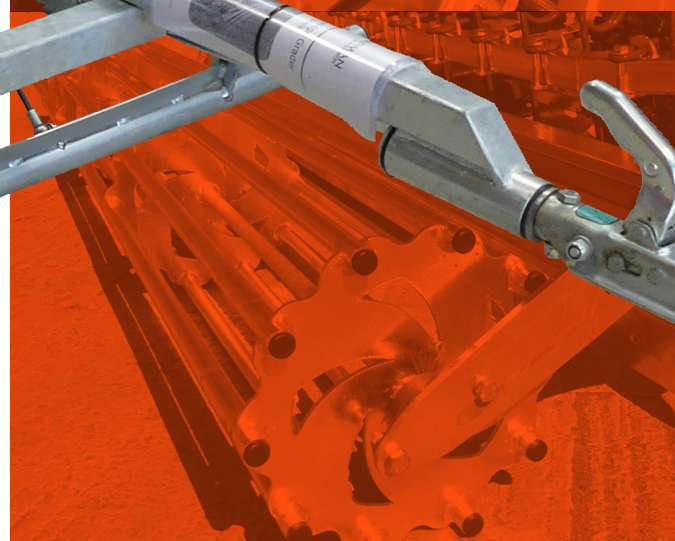

**The MG250 Arena Leveller is the perfect tool for levelling and grading all types of equestrian riding surface. Designed for ease of use and robust build, the MG250 will restore and maintain a top quality riding surface quickly and easily.**

Built around a robust A-frame design, the MG250 can be supplied as a towed unit for use behind ATVs, 4x4s and large lawnmowers, or as a fully mounted unit for use behind a compact or mid-sized tractor.

Robust construction and a quality finish ensures years of trouble-free ownership and a consistent riding surface. Our unique work / transport modes allow you to maintain the grading depth consistently, and to easily change between modes using the integrated lever.

#### TECHNICAL FEATURES

- Robust 2" box section steel frame for durability
- Large flotation tyres for smooth travel over uneven arenas
- Heavy duty 0.5inch agitation tines
- Perimeter blade
- Integrated running board wheels
- Transport / work modes for repeatable grading results
- Hardened levelling blade
- Rear Consolidation Roller

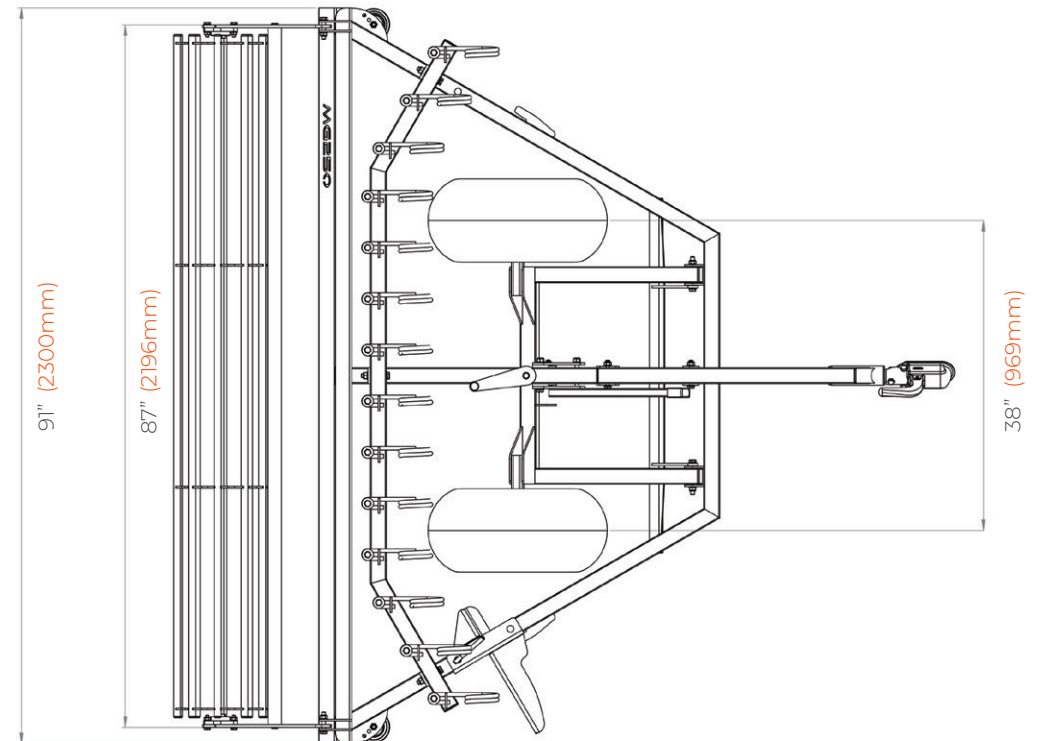
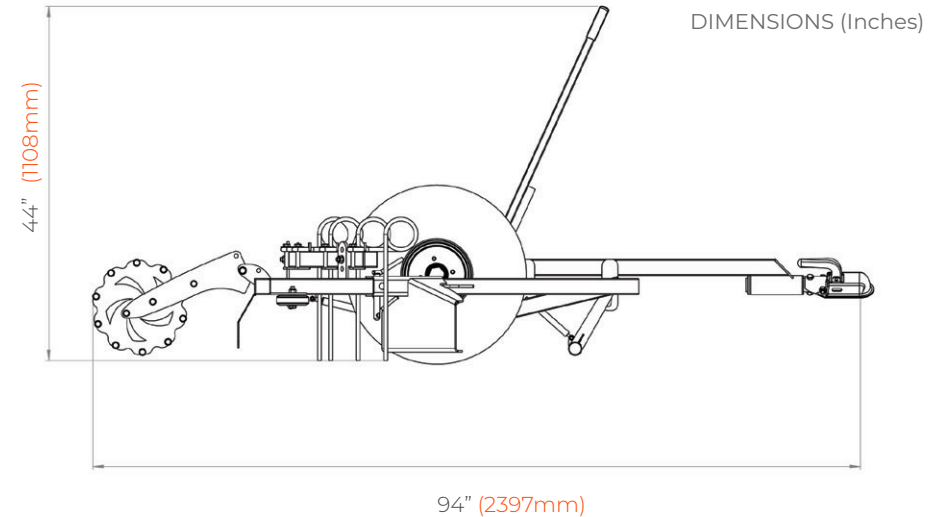

# CHAPMAN

HEAVY DUTY ATV MACHINERY

US/Canada Agent: 4510 State Route 52, Jeffersonville, NY 12748, USA  
Tel: +1 (845) 482-5222

Head Office: Hele Barton, Week St. Mary, Holsworthy, Devon, UK, EX22 6XR  
Tel: +44(0)1288 308149



[WWW.CHAPMANMACHINERY.COM](http://WWW.CHAPMANMACHINERY.COM)

[sales@chapmanmachinery.com](mailto:sales@chapmanmachinery.com)